

Application of Zenith t-Branch system in symptomatic thoracoabdominal aortic aneurysm with unfavourable anatomy — case report

Piotr Hammer¹, Tomasz Jakimowicz², Lukasz Romanowski²,
Krzysztof Lukawski², Michal Macech², Slawomir Nazarewski²

¹Hammermed, Cook Medical Consultant, Warsaw, Poland

²Department of General, Vascular and Transplant Surgery, Medical University of Warsaw, Poland

Abstract

Although huge improvement has been observed in endovascular repair of aneurysms involving visceral arteries, in urgent cases open repair remained a method of choice. The aim was to present a patient with symptomatic thoracoabdominal aortic aneurysm measuring 11 cm in diameter (Crawford III). Due to concomitant medication and morphology of aorta, there was neither possibility for open repair, nor for standard stent-graft implantation. We decided to apply Zenith t-Branch system, though visceral arteries anatomy haven't met morphological criteria from instruction for use (IFU) and previous guidelines — patient had critically stenosed coeliac trunk, steep left renal artery, blood to right kidney was supplied through the thick thrombus and two extra kidney arteries to the lower pole were present. At first, balloon was placed into the right renal artery to protect it from embolization. Next, after Zenith Tx2 stent-graft deployment, t-Branch system was implanted. Through branch dedicated to coeliac trunk, left kidney artery was bridged using Advanta stents. Superior mesenteric artery and right kidney artery were bridged by appropriate branches. All bridges were reinforced by Zilver stents. Branch dedicated to left renal artery was occluded using Amplatzer plug. Postoperative recovery and 4-month follow-up was uneventful. In control computed tomography performed at third month shrinking of the sac was observed to 96 mm and low-pressure type II endoleak between coeliac trunk and additional left renal arteries has been left for further observation. Application of Zenith t-Branch is feasible and efficient method of treatment in urgent cases, even if visceral arteries anatomy is outside IFU.

Key words: thoracoabdominal aortic aneurysm, endovascular repair, t-Branch, stent-graft

Acta Angiol 2015; 21, 2: 47–52

Introduction

First case report of endovascular juxtarenal aneurysm repair has been published in 1996 [1]. Since then, for nearly two decades tremendous improvement has been observed in the treatment of aneurysms involving visceral arteries [2, 3]. Fenestrated and branched

stent-grafts have nowadays established position and are valuable alternative compared to open repair, which is demanding even for the most experienced centres [4, 5]. On the beginning all branched and fenestrated stent-grafts were custom-made (custom-made device, CMD), and required up to 6–8 weeks for manufacture and delivery. The time restriction precluded application

Address for correspondence: Tomasz Jakimowicz, Department of General, Vascular and Transplant Surgery, Medical University of Warsaw, Banacha 1A, 02–097 Warsaw

endovascular method in case of symptomatic or ruptured aneurysms. The need of solution in such cases led to produce Zenith t-Branch device (Cook Medical, Bloomington, IN, USA). Based on previous studies [6, 7] it was proven that more than half of the patients meet criteria for endovascular repair of thoracoabdominal aneurysms (multibranched endovascular aneurysm repair, mbEVAR) using Zenith t-Branch. Recently, it has also received CE approval.

The aim of the study was to present the case of Zenith t-Branch application in endovascular treatment of 11-cm thoracoabdominal aneurysm that hasn't met morphological criteria specified in the manufacturer's instruction for use.

Case study

C.W., 71-year-old patient with abdominal pain was admitted to surgical ward of the local hospital. In anamnesis, patient had open surgery due to ruptured infrarenal aortic aneurysm 10 years ago, complicated by myocardial infarction two days after operation and sigmoid necrosis with temporary colostomy formation five days after surgery. In addition, patient suffered COPD and stable myocardial angina. Diagnostic computed tomography (AngioCT) revealed eleven centimetres TAAA — Crawford III, originating 25.9 cm distally to left subclavian artery extending to the anastomosis of previously implanted bifurcated vascular graft. There were no other causes of abdominal pain; therefore patient was immediately transferred to our Department.

Because of previous extensive abdominal operations and general co-morbidities, patient was disqualified from open repair of TAAA. Moreover, preoperative AngioCT revealed critical stenosis in the orifice of coeliac trunk (CT) (Fig. 1) and additional, two small arteries to the inferior pole of left kidney (Fig. 2). Blood supply to the right kidney had extra difficulty — blood was brought via 21 mm of thrombus inside the aneurysm (Fig. 3). Additionally, the angle of the right renal artery was very steep (Fig. 4). According to the instruction for use (IFU) and guidelines from previous studies [6, 8], abovementioned conditions excluded patient from Zenith t-Branch usage. But taking into consideration high risk of the rupture, waiting for CMD was very hazardous option for this patient. Therefore we decided to apply Zenith t-Branch beyond the instruction for use. The device is a multi-branch stent-graft 32 mm in upper and 18 mm in lower diameter. It has dedicated four branches for each visceral artery in a specific distance and clock rotation. Outline of the graft is presented in Figure 5. Relations of patient's visceral arteries anatomy are presented schematically in Figure 6 and in Table I.

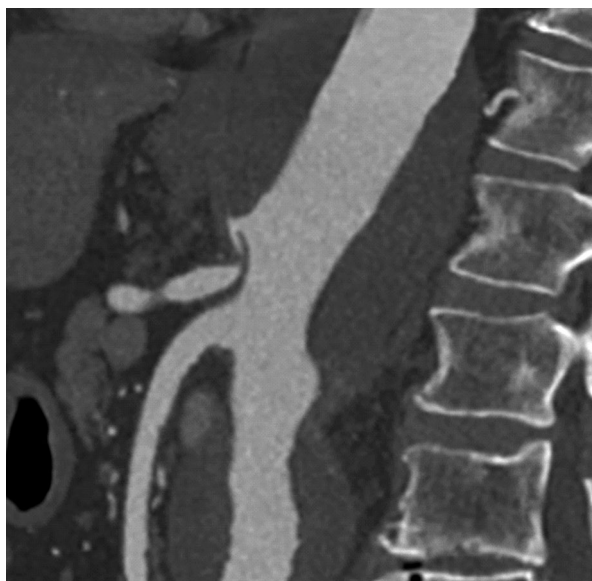

Figure 1. Preoperative AngioCT scan presents critically stenosed coeliac trunk



Figure 2. Preoperative AngioCT scan presents two additional renal arteries to the inferior pole

The operation started with introduction of 24 F sheath through left femoral artery and insertion guide-wire (Terumo) to superior mesenteric artery (SMA) to mark its orifice. Next, by the valve puncture 6 mm/8 cm balloon was placed into right renal artery (RRA) as a protection of its embolization during stent-graft placement. Another puncture of the valve allowed placing calibrated pig-tail catheter to aorta (Fig. 7). Next, via right femoral artery Zenith TX2 (32 × 209 mm) was

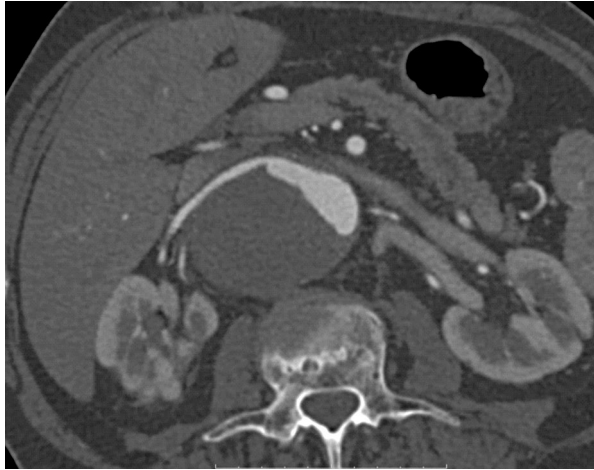

Figure 3. Preoperative CT scan presents blood supply via massive thrombus inside the aneurysm



Figure 4. Intraoperative angiography presenting steep angle of right renal artery and balloon introduced inside as embolization protection

deployed 4 cm above SMA (CT was critically stenosed). Then, after insertion of long (380 cm) hydrophilic guidewire passing through left brachial artery and right femoral artery, Zenith t-Branch was inserted and deployed with CT branch 1 cm above SMA. Subsequently it was prolonged with straight stent-graft Zenith Alpha 24×105 mm that ended in the bifurcated graft.

Afterwards, via left brachial artery, bridging stents (Fluency Bard Peripheral Vascular, Tempe, USA reinforced with bare self-expandable Zilver Cook stents) to SMA and right renal artery were deployed from ad-

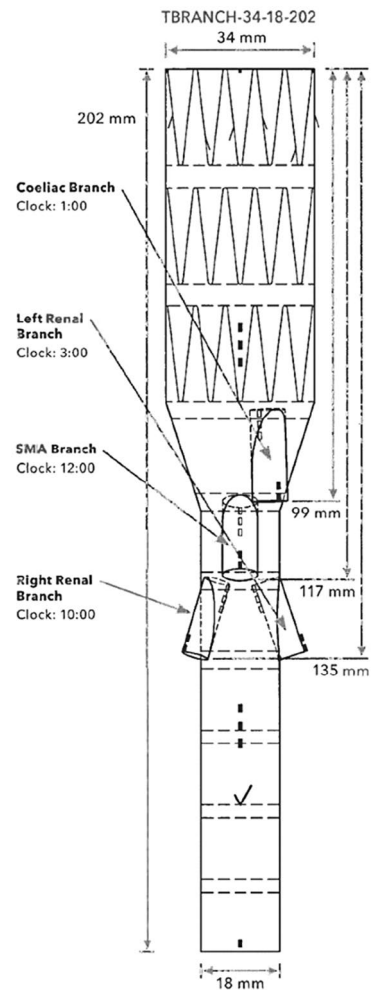

Figure 5. Scheme of the Zenith t-Branch [23]

equate branches. Main left renal artery was cannulated via branch referred to coeliac trunk and bridged on two balloon-expandable Advanta stents (Atrium Medical, USA) 6×38 mm and 9×59 mm. Afterwards stents were reinforced by self-expandable Zilver stent 6×80 mm. Branch referred to left renal artery (LRA) was closed by Amplatzer Vascular Plug 4 (St. Jude Medical, USA) 4×8 mm. Additional renal arteries were not cannulated due to its small diameter (1 mm each) and minor influence for kidney sufficiency. It has not even appeared in aneurysm sacography before branch closure. Final angiography showed proper contrast perfusion through stent-grafts and branches and small, late leakage, probably through not yet thrombosed Amplatzer (patient was on heparine infusion with ACT raised to 250–300 sec). Blood flow to branches of coeliac trunk was good, provided by expanded gastro-duodenal artery. Total operation time was 290 minutes, radiation time 94.4 min, radiation dose 35.7 mGy/m^2 . Postoperative period was not complicated with 1-day intensive care unit

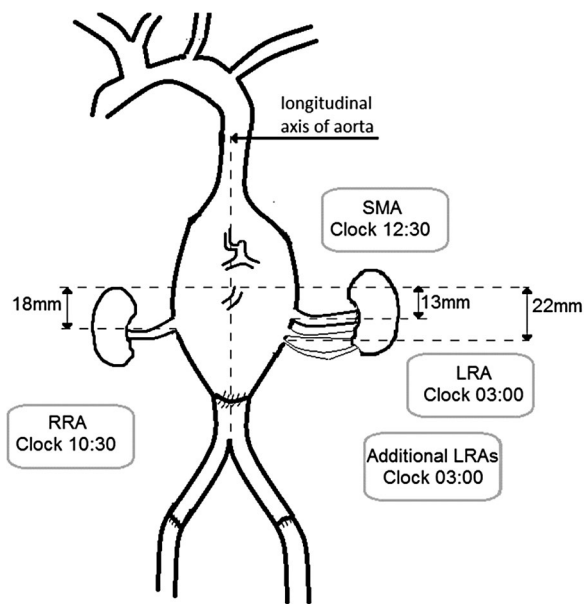

Figure 6. Scheme of the visceral arteries anatomy

Table I. Orifices and distances of visceral arteries

Artery	Clock position	Distance from SMA ostium
CT	Critically stenosed	
SMA	12:30	0
LRA	03:00	13 mm
RRA	10:30	18 mm
Additional LRAs	03:00	22 mm

and 6-days in-hospital stay. Four months follow-up was uneventful. Follow-up AngioCT at third month revealed type II endoleak leak from surprisingly patent, extremely compressed coeliac trunk and (or going into) one of additional renal arteries. The Amplatzer was thrombosed. Since maximum diameter reduced to 96 mm, the leak was left for further observation.

Discussion

Endovascular repair, both of isolated thoracic and infrarenal aortic aneurysms, are well-known, approved methods of treatment [9–13]. In contrary, in case of TAAA open operation was considered a “gold standard” despite the risk of morbidity and mortality [14]. Recently, mbEVAR became valuable alternative to open operation. Chuter et al. [15] as a first demonstrated that results of mbEVAR are satisfactory with 9.1% perioperative mortality and freedom-from-reintervention index 90.8% in one year follow-up.

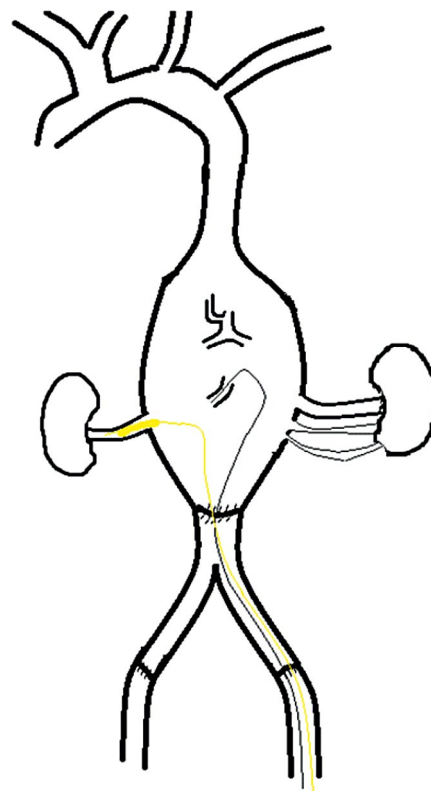

Figure 7. Schematic picture presents aneurysm sac with SMA marked by Terumo guidewire and balloon introduced to right renal artery

Formerly, the main limitation in mbEVAR usage was the time for manufacture and delivery of stent-graft due to variances of visceral arteries anatomy. Gasper [6] and Bisdas [7] retrospectively assessed preoperative AngioCT of elective patients who underwent mbEVAR using CMD. Their relevant results showed that nearly two-thirds of patients (66% and 63%, respectively) where suitable to apply t-Branch, as the method of TAAA treatment.

IFU [8] requires, inter alia, suitable visceral arteries anatomy:

- four indispensable arteries from the abdominal viscera;
- all target arteries to be accessible from an antegrade approach;
- CT and SMA to be 6 to 10 mm in diameter;
- renal arteries to be 4 to 8 mm in diameter;
- the distance between each cuff and the corresponding arterial orifice is less than 50 mm;
- the line between the cuff and the arterial orifice as projected onto the vessel wall deviates by no more than 45 degrees from the long axis of the aorta.

Moreover, IFU makes a precaution that t-Branch was not evaluated among patients with symptomatic and ruptured TAAA. Our patient was not suitable to

t-Branch due to most above-mentioned points. He had symptomatic TAAA, with obstructed CT. What is more, LRA couldn't have been cannulated from the dedicated cuff, because its level was too high and if the t-Branch would have been placed higher, all other branches would be even more difficult to cannulate. In addition, angle between stent deployed to right renal artery and long axis of aorta was greater than 90 degrees. Unused cuff for left renal artery was embolised by Amplatzer. The closure of the cuff is not mentioned in the IFU, however described in the literature by the application of "coils" [16].

Bisdas et al. [17] compared results of the application CMD and t-Branch endograft in elective patients with TAAA. Although perioperative success was complete in both groups, mortality was higher in group treated with CMD ($p = 0.04$). What is more, in six months observation none of the patient treated with t-Branch system needed reintervention, while 10% of the other group needed secondary procedure ($p = 0.07$). In the summary authors highlights indisputable availability of the t-Branch system and good short-term outcomes.

Another essential issue to discuss in this case report is surveillance after open repair of abdominal aortic aneurysm (AAA). Presented patient haven't had any ultrasound examination to assess aortic diameter above anastomosis for 10 years. Fontaine et al. [18], observed aneurysm formation proximally to the prosthesis in 32% of patients 10.3 years after AAA repair. Biancari et al. [19] found that in 15 year follow-up 12.5% of study group had any new aortic aneurysm and nearly 3% of all had TAAA. Thus, after open operation of AAA all patients must be under surveillance with at least periodic ultrasound examination.

"Chimney" technique, and its further modification — "periscope", are alternatives in urgent symptomatic and ruptured TAAA. In presented case we did not decide to use it due to longitudinal size of the aneurysm [14]. Moreover, multicentre study of Lachat et al. [21] showed that 25% of patients who had above-mentioned techniques, at the time of discharge had endoleaks type I and III. Though during follow-up most of the leaks thrombosed spontaneously, it was considerable risk of postoperative rupture of 11-cm aneurysm in early period. On the other hand, chimney technique is known as safer in case of substantial thickness of intramural thrombus [22]. Manoeuvres before and during deployment during mbEVAR may cause embolization of target vessels. That was the reason of balloon placement in RRA before t-Branch deployment.

Conclusion

We can conclude that in urgent situation the application of Zenith t-Branch stent-graft outside the anatomical

requirements is feasible and could be good treatment option for TAAA.

References

1. Park J H, Chung JW, Choo IW, Kim SJ, Lee JY, Han MC (1996) Fenestrated stent-grafts for preserving visceral arterial branches in the treatment of abdominal aortic aneurysms: preliminary experience. *J Vasc Intervention Radiol*; 7: 819–823.
2. Guillou M, Bianchini A, Sobocinski J et al (2012) Endovascular treatment of thoracoabdominal aortic aneurysms. *J Vasc Surg*; 56: 65–73.
3. Verhoeven ELG, Vourliotakis G, Bos WTGJ et al (2010) Fenestrated stent grafting for short-necked and juxtarenal abdominal aortic aneurysm: an 8-year single-centre experience. *Eur J Vasc Endovasc Surg*; 39: 529–536.
4. Coselli JS, Bozinovski J, LeMaire SA (2007) Open surgical repair of 2286 thoracoabdominal aortic aneurysms. *Ann Thoracic Surg*; 83: S862–S864.
5. Conrad MF, Crawford RS, Davison JK, Cambria RP (2007) Thoracoabdominal aneurysm repair: a 20-year perspective. *Ann Thoracic Surg*; 83: S856–S861.
6. Gasper WJ, Reilly LM, Rapp JH et al (2013) Assessing the anatomic applicability of the multibranch endovascular repair of thoracoabdominal aortic aneurysm technique. *J Vasc Surg*; 57: 1553–1558.
7. Bisdas T, Donas KP, Bosiers M, Torsello G, Austermann M (2013) Anatomical suitability of the t-Branch stent-graft in patients with thoracoabdominal aortic aneurysms treated using custom-made multibranch endografts. *J Endovasc Ther*; 20: 672–677.
8. https://ifu.cookmedical.com/ifuPub/ReadFile?fileName=IFU-TBR_V7.PDF
9. De Bruin JL, Baas AF, Buth J et al (2010) Long-term outcome of open or endovascular repair of abdominal aortic aneurysm. *N Engl J Med*; 362: 1881–1889.
10. Greenhalgh RM, The EVAR Investigators (2004) Comparison of endovascular aneurysm repair with open repair in patients with abdominal aortic aneurysm (EVAR trial 1), 30-day operative mortality results: randomised controlled trial. *Lancet*; 364: 843–848.
11. Chang RW, Goodney P, Tucker LY et al (2013) Ten-year results of endovascular abdominal aortic aneurysm repair from a large multicenter registry. *J Vasc Surg*; 58: 324–332.
12. Shah AA, Barfield ME, Andersen ND et al (2012) Results of thoracic endovascular aortic repair 6 years after United States Food and Drug Administration approval. *Ann Thoracic Surg* 94: 1394–1399.
13. Matsumura JS, Melissano G, Cambria RP et al (2014) Five-year results of thoracic endovascular aortic repair with the Zenith TX2. *J Vasc Surg*; 60: 1–10.
14. Barillà D, Guillou M, Maurel B et al (2013) Off-the-shelf branched endograft for emergent aneurysm repair. *Ann Vasc Surg*; 27: 972–e11.
15. Chuter TA, Rapp JH, Hiramoto JS, Schneider DB, Howell B, Reilly LM (2008) Endovascular treatment of thoracoabdominal aortic aneurysms. *J Vasc Surg*; 47: 6–16.
16. Ferreira M, Lanzio L, Monteiro M (2008) Branched devices for thoracoabdominal aneurysm repair: early experience. *J Vasc Surg*; 48: 30S–36S.
17. Bisdas T, Donas KP, Bosiers MJ, Torsello G, Austermann M (2014) Custom-made versus off-the-shelf multibranch end-

- dografts for endovascular repair of thoracoabdominal aortic aneurysms. *J Vasc Surg*; 60: 1186–1195.
18. Fontaine R, Kolh P, Creemers E et al (2008) Open surgery for abdominal aortic aneurysm or aorto-iliac occlusive disease — clinical and ultrasonographic long-term results. *Acta Chirurg Belg*; 108: 393–399.
 19. Biancari F, Ylönen K, Anttila V et al (2002) Durability of open repair of infrarenal abdominal aortic aneurysm: a 15-year follow-up study. *J Vasc Surg*; 35: 87–93.
 20. Kolvenbach RR, Yoshida R, Pinter L, Zhu Y, Lin F (2011) Urgent endovascular treatment of thoraco-abdominal aneurysms using a sandwich technique and chimney grafts — a technical description. *Eur J Vasc Endovasc Surg*; 41: 54–60.
 21. Lachat M, Veith FJ, Pfammatter T et al (2013) Chimney and periscope grafts observed over 2 years after their use to revascularize 169 renovisceral branches in 77 patients with complex aortic aneurysms. *J Endovasc Ther*; 20: 597–605.
 22. Orr N, Minion D, Bobadilla JL (2014) Thoracoabdominal aortic aneurysm repair: current endovascular perspectives. *Vasc Health Risk Manag*; 10: 493.
 23. Cook t-Branch Device Selection Form, AI-AMF-TBR-SOF-EN-201211, www.cookmedical.com.